

PROSTAGE

control without limits!

USERS MANUAL



CONTROLLER Pedal XCC BlackLine

www.prostage.eu
info@prostage.eu

Controller Pedal XCC

General Information

What is MIDI?

MIDI stands for "Music Instrument Digital Interface". MIDI is the global standard for transmitting notes and control commands to and from all kinds of electronic instruments and sound-processing equipment.

MIDI is a serial interface which only transmits control information - not audio data - between music instruments and devices. For example, if you connect a keyboard to a computer via MIDI, the computer, respectively the sequencer software can play the keyboard. The sequencer tells the keyboard which sound should be played with what velocity at what time. In other words, the computer is practically pressing the keys. The sound is not transmitted by MIDI, but is formed by the keyboard. It is also possible, of course, to connect several devices together.

Besides notes, MIDI can transmit all kinds of control commands. For example, the Sequencer tells the keyboard what volume the subsequent notes should be played at. To this end, the sequencer sends Control Change command #7 with the value of the level (1-127).

Using these Control Change commands, the value of numerous parameters can be changed in realtime. The Prostage Controller Pedal XCC does nothing else than transmit these Control Change commands. Thus, you can e.g. control a WhaWha effect, the mix of the effect or the level of the unit you control.

Controller Pedal XCC Users Manual

1. Connection of the Controller Pedal XCC

The Prostage™ MIDI equipment is interconnected using standard microphone cables (not supplied). You can use any microphone cable available on the market. If you choose quality cables, then cable lengths of up to 100m work troublefree. Also transmission over a single-shielded multicore is no problem. The microphone cable not only transmits the MIDI signal but supplies the Controller Pedal with power as well. You do not require a separate power supply for the XCC. It can be used "stand alone" or be connected to a Prostage Foot Controller. The microphone cable can be extended as required. Important: Make sure the microphone cables are wired correctly. The Prostage equipment does not work with cables that are wired phase reversed (microphones still work with these cables).

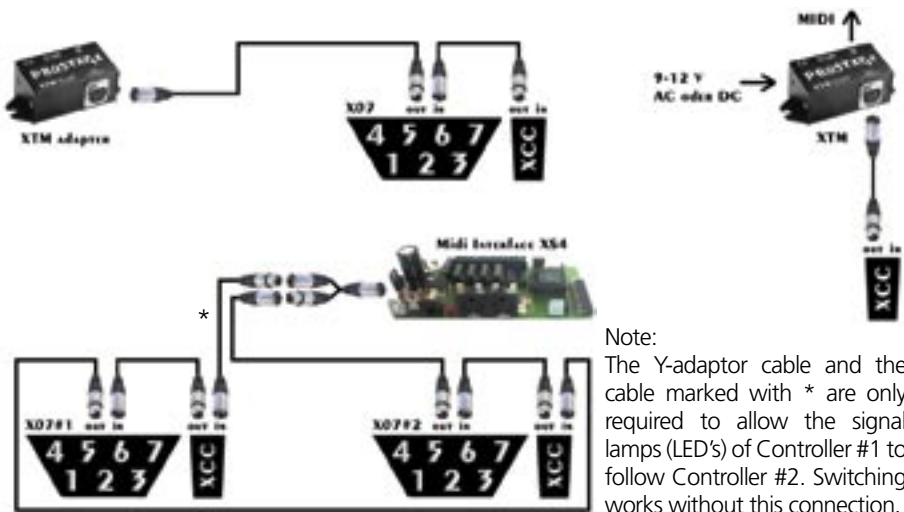

2. Connection of the XTM Adaptor

Connect an AC power adaptor to the power input (labeled AC or DC In) of the XTM adaptor. You can use any power supply unit with 9-12 V AC or DC output. The power supply must supply at least 20mA per connected Controller XCC. Connect the MIDI Out of the XTM adaptor to the MIDI In of your equipment using a standard MIDI cable. Connect your Controller pedal using a microphone cable to the XTM adaptor.

3. Function of the Controller Pedal XCC

Everytime you move (tilt) the Controller Pedal XCC, it sends a Control Change, Pitch Bend or Aftertouch value (the actual position of the Pedal). The following chapter describes which command is sendt in detail:

4. Settings of the Controller Pedal XCC

Inside the Controller Pedal there are dip-switches which allow you to set the functionality of your XCC. Caution: Take care when you open the housing of the Controller Pedal: do not tear off the wires connected to the XLR connectors! We recommend to have this work carried out by a (guitar) technician. Some settings only become operational after the power has been turned off and on again. Following settings can be chosen:

Decoder PCB (movement detector)

Switch 1-4 Chooses the MIDI transmit channel as listed below.

MIDI CH	Switch1	Switch 2	Switch 3	Switch 4
1	OFF	OFF	OFF	OFF
2	ON	OFF	OFF	OFF
3	OFF	ON	OFF	OFF
4	ON	ON	OFF	OFF
5	OFF	OFF	ON	OFF
6	ON	OFF	ON	OFF
7	OFF	ON	ON	OFF
8	ON	ON	ON	OFF
9	OFF	OFF	OFF	ON
10	ON	OFF	OFF	ON
11	OFF	ON	OFF	ON
12	ON	ON	OFF	ON
13	OFF	OFF	ON	ON
14	ON	OFF	ON	ON
15	OFF	ON	ON	ON
16	ON	ON	ON	ON

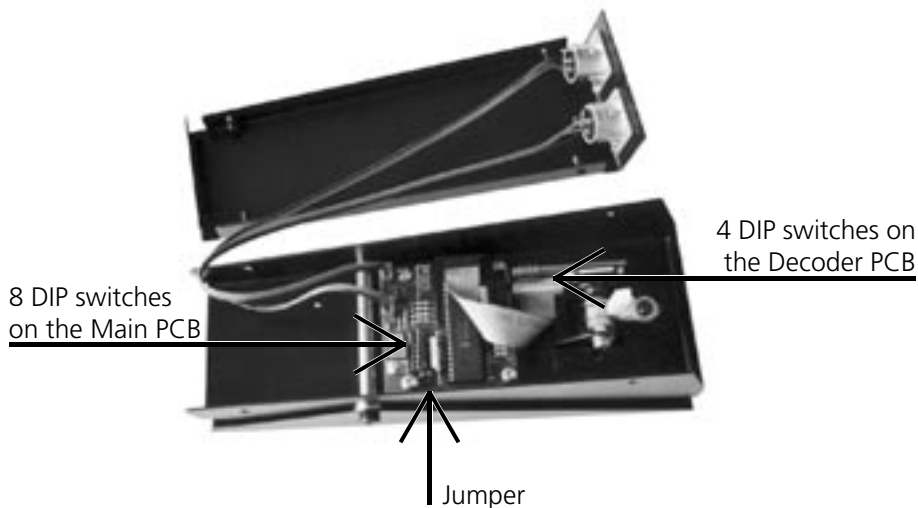

Main PCB

Switch 1-7 Chooses the commands to be sent. (see 4.1 and 4.2)

Switch 8 Chooses between Control Change / Aftertouch or Pitch Bend
 OFF = The Pedal sends Control Change commands according to the table on pages 6-9. If Control Change number 120-127 is selected, the Pedal sends monophone aftertouch.
 ON = The Pedal sends Pitch Bend according to table on page 10.

Jumper Chooses the working direction of the Pedal
 OFF = Pedal down => hi value (127)
 Pedal up => low value (0)
 ON = Pedal down => low value (0)
 Pedal up => hi value (127)

=> Default setting is "Volume" (Controller # 7) sent on MIDI channel 1.

4.1 Operating mode "Control Change / Aftertouch"

If DIP-switch 8 is set to "OFF", the Controller Pedal XCC sends Control Change commands according to the table on the following 4 pages. If you set a Controller number between 120 and 127, the XCC sends monophone Aftertouch instead of Control Change commands.

Switch 1-7 Chooses the Controller number according to the following list:

Controller	Nr.	DIP-Switch						
		1	2	3	4	5	6	7
Bank Select	0	OFF	OFF	OFF	OFF	OFF	OFF	OFF
Modulation Wheel	1	ON	OFF	OFF	OFF	OFF	OFF	OFF
Breath Controller	2	OFF	ON	OFF	OFF	OFF	OFF	OFF
not defined	3	ON	ON	OFF	OFF	OFF	OFF	OFF
Foot Controller	4	OFF	OFF	ON	OFF	OFF	OFF	OFF
Portamento Time	5	ON	OFF	ON	OFF	OFF	OFF	OFF
Data Entry	6	OFF	ON	ON	OFF	OFF	OFF	OFF
Main Volume	7	ON	ON	ON	OFF	OFF	OFF	OFF
Balance	8	OFF	OFF	OFF	ON	OFF	OFF	OFF
not defined	9	ON	OFF	OFF	ON	OFF	OFF	OFF
Panorama	10	OFF	ON	OFF	ON	OFF	OFF	OFF
Expression Contr.	11	ON	ON	OFF	ON	OFF	OFF	OFF
Control 1	12	OFF	OFF	ON	ON	OFF	OFF	OFF
Control 2	13	ON	OFF	ON	ON	OFF	OFF	OFF
not defined	14	OFF	ON	ON	ON	OFF	OFF	OFF
not defined	15	ON	ON	ON	ON	OFF	OFF	OFF
General Purpose 1	16	OFF	OFF	OFF	OFF	ON	OFF	OFF
General Purpose 2	17	ON	OFF	OFF	OFF	ON	OFF	OFF
General Purpose 3	18	OFF	ON	OFF	OFF	ON	OFF	OFF
General Purpose 4	19	ON	ON	OFF	OFF	ON	OFF	OFF
not defined	20	OFF	OFF	ON	OFF	ON	OFF	OFF
not defined	21	ON	OFF	ON	OFF	ON	OFF	OFF
not defined	22	OFF	ON	ON	OFF	ON	OFF	OFF
not defined	23	ON	ON	ON	OFF	ON	OFF	OFF
not defined	24	OFF	OFF	OFF	ON	ON	OFF	OFF
not defined	25	ON	OFF	OFF	ON	ON	OFF	OFF
not defined	26	OFF	ON	OFF	ON	ON	OFF	OFF
not defined	27	ON	ON	OFF	ON	ON	OFF	OFF
not defined	28	OFF	OFF	ON	ON	ON	OFF	OFF
not defined	29	ON	OFF	ON	ON	ON	OFF	OFF
not defined	30	OFF	ON	ON	ON	ON	OFF	OFF
not defined	31	ON	ON	ON	ON	ON	OFF	OFF

Controller	Nr.	DIP-Switch						
		1	2	3	4	5	6	7
LSB Controller #0	32	OFF	OFF	OFF	OFF	OFF	ON	OFF
LSB Controller #1	33	ON	OFF	OFF	OFF	OFF	ON	OFF
LSB Controller #2	34	OFF	ON	OFF	OFF	OFF	ON	OFF
LSB Controller #3	35	ON	ON	OFF	OFF	OFF	ON	OFF
LSB Controller #4	36	OFF	OFF	ON	OFF	OFF	ON	OFF
LSB Controller #5	37	ON	OFF	ON	OFF	OFF	ON	OFF
LSB Controller #6	38	OFF	ON	ON	OFF	OFF	ON	OFF
LSB Controller #7	39	ON	ON	ON	OFF	OFF	ON	OFF
LSB Controller #8	40	OFF	OFF	OFF	ON	OFF	ON	OFF
LSB Controller #9	41	ON	OFF	OFF	ON	OFF	ON	OFF
LSB Controller #10	42	OFF	ON	OFF	ON	OFF	ON	OFF
LSB Controller #11	43	ON	ON	OFF	ON	OFF	ON	OFF
LSB Controller #12	44	OFF	OFF	ON	ON	OFF	ON	OFF
LSB Controller #13	45	ON	OFF	ON	ON	OFF	ON	OFF
LSB Controller #14	46	OFF	ON	ON	ON	OFF	ON	OFF
LSB Controller #15	47	ON	ON	ON	ON	OFF	ON	OFF
LSB Controller #16	48	OFF	OFF	OFF	OFF	ON	ON	OFF
LSB Controller #17	49	ON	OFF	OFF	OFF	ON	ON	OFF
LSB Controller #18	50	OFF	ON	OFF	OFF	ON	ON	OFF
LSB Controller #19	51	ON	ON	OFF	OFF	ON	ON	OFF
LSB Controller #20	52	OFF	OFF	ON	OFF	ON	ON	OFF
LSB Controller #21	53	ON	OFF	ON	OFF	ON	ON	OFF
LSB Controller #22	54	OFF	ON	ON	OFF	ON	ON	OFF
LSB Controller #23	55	ON	ON	ON	OFF	ON	ON	OFF
LSB Controller #24	56	OFF	OFF	OFF	ON	ON	ON	OFF
LSB Controller #25	57	ON	OFF	OFF	ON	ON	ON	OFF
LSB Controller #26	58	OFF	ON	OFF	ON	ON	ON	OFF
LSB Controller #27	59	ON	ON	OFF	ON	ON	ON	OFF
LSB Controller #28	60	OFF	OFF	ON	ON	ON	ON	OFF
LSB Controller #29	61	ON	OFF	ON	ON	ON	ON	OFF
LSB Controller #30	62	OFF	ON	ON	ON	ON	ON	OFF
LSB Controller #31	63	ON	ON	ON	ON	ON	ON	OFF

Controller	Nr.	DIP-Switch						
		1	2	3	4	5	6	7
Sustain Pedal	64	OFF	OFF	OFF	OFF	OFF	OFF	ON
Portamento ON/OFF	65	ON	OFF	OFF	OFF	OFF	OFF	ON
Sostenuto	66	OFF	ON	OFF	OFF	OFF	OFF	ON
Soft Pedal	67	ON	ON	OFF	OFF	OFF	OFF	ON
Legato Footswitch	68	OFF	OFF	ON	OFF	OFF	OFF	ON
Hold 2	69	ON	OFF	ON	OFF	OFF	OFF	ON
Sound Variation	70	OFF	ON	ON	OFF	OFF	OFF	ON
Harmonic Content	71	ON	ON	ON	OFF	OFF	OFF	ON
Release Time	72	OFF	OFF	OFF	ON	OFF	OFF	ON
Attack Time	73	ON	OFF	OFF	ON	OFF	OFF	ON
Brightness	74	OFF	ON	OFF	ON	OFF	OFF	ON
Sound Contr. #6	75	ON	ON	OFF	ON	OFF	OFF	ON
Sound Contr. #7	76	OFF	OFF	ON	ON	OFF	OFF	ON
Sound Contr. #8	77	ON	OFF	ON	ON	OFF	OFF	ON
Sound Contr. #9	78	OFF	ON	ON	ON	OFF	OFF	ON
Sound Contr. #10	79	ON	ON	ON	ON	OFF	OFF	ON
General Purpose 5	80	OFF	OFF	OFF	OFF	ON	OFF	ON
General Purpose 6	81	ON	OFF	OFF	OFF	ON	OFF	ON
General Purpose 7	82	OFF	ON	OFF	OFF	ON	OFF	ON
General Purpose 8	83	ON	ON	OFF	OFF	ON	OFF	ON
not defined	84	OFF	OFF	ON	OFF	ON	OFF	ON
not defined	85	ON	OFF	ON	OFF	ON	OFF	ON
not defined	86	OFF	ON	ON	OFF	ON	OFF	ON
not defined	87	ON	ON	ON	OFF	ON	OFF	ON
not defined	88	OFF	OFF	OFF	ON	ON	OFF	ON
not defined	89	ON	OFF	OFF	ON	ON	OFF	ON
not defined	90	OFF	ON	OFF	ON	ON	OFF	ON
Reverb Depth	91	ON	ON	OFF	ON	ON	OFF	ON
Tremolo Depth	92	OFF	OFF	ON	ON	ON	OFF	ON
Chorus Depth	93	ON	OFF	ON	ON	ON	OFF	ON
Detune Depth	94	OFF	ON	ON	ON	ON	OFF	ON
Phaser Depth	95	ON	ON	ON	ON	ON	OFF	ON

Controller	Nr.	DIP-Switch						
		1	2	3	4	5	6	7
Data Increment	96	OFF	OFF	OFF	OFF	OFF	ON	ON
Data Decrement	97	ON	OFF	OFF	OFF	OFF	ON	ON
Non-Reg. LSB	98	OFF	ON	OFF	OFF	OFF	ON	ON
Non-Reg. MSB	99	ON	ON	OFF	OFF	OFF	ON	ON
Reg. Para. LSB	100	OFF	OFF	ON	OFF	OFF	ON	ON
Reg. Para. MSB	101	ON	OFF	ON	OFF	OFF	ON	ON
not defined	102	OFF	ON	ON	OFF	OFF	ON	ON
not defined	103	ON	ON	ON	OFF	OFF	ON	ON
not defined	104	OFF	OFF	OFF	ON	OFF	ON	ON
not defined	105	ON	OFF	OFF	ON	OFF	ON	ON
not defined	106	OFF	ON	OFF	ON	OFF	ON	ON
not defined	107	ON	ON	OFF	ON	OFF	ON	ON
not defined	108	OFF	OFF	ON	ON	OFF	ON	ON
not defined	109	ON	OFF	ON	ON	OFF	ON	ON
not defined	110	OFF	ON	ON	ON	OFF	ON	ON
not defined	111	ON	ON	ON	ON	OFF	ON	ON
not defined	112	OFF	OFF	OFF	OFF	ON	ON	ON
not defined	113	ON	OFF	OFF	OFF	ON	ON	ON
not defined	114	OFF	ON	OFF	OFF	ON	ON	ON
not defined	115	ON	ON	OFF	OFF	ON	ON	ON
not defined	116	OFF	OFF	ON	OFF	ON	ON	ON
not defined	117	ON	OFF	ON	OFF	ON	ON	ON
not defined	118	OFF	ON	ON	OFF	ON	ON	ON
not defined	119	ON	ON	ON	OFF	ON	ON	ON
Aftertouch (mono)	120	OFF	OFF	OFF	ON	ON	ON	ON
Aftertouch (mono)	121	ON	OFF	OFF	ON	ON	ON	ON
Aftertouch (mono)	122	OFF	ON	OFF	ON	ON	ON	ON
Aftertouch (mono)	123	ON	ON	OFF	ON	ON	ON	ON
Aftertouch (mono)	124	OFF	OFF	ON	ON	ON	ON	ON
Aftertouch (mono)	125	ON	OFF	ON	ON	ON	ON	ON
Aftertouch (mono)	126	OFF	ON	ON	ON	ON	ON	ON
Aftertouch (mono)	127	ON	ON	ON	ON	ON	ON	ON

4.2 Operation mode "Pitch Bend"

If DIP-Switch 8 (see page 5) is set to "ON", the Pedal sends Pitch Bend according to the following list:

Switch 1-4 Chooses the range of pitch.

	semitone steps	Switch 1	Switch 2	Switch 3	Switch 4
minor 2 nd	1	OFF	OFF	OFF	OFF
major 2 nd	2	ON	OFF	OFF	OFF
minor 3 rd	3	OFF	ON	OFF	OFF
major 3 rd	4	ON	ON	OFF	OFF
perfect 4 th	5	OFF	OFF	ON	OFF
diminished 5 th	6	ON	OFF	ON	OFF
perfect 5 th	7	OFF	ON	ON	OFF
minor 6 th	8	ON	ON	ON	OFF
major 6 th	9	OFF	OFF	OFF	ON
minor 7 th	10	ON	OFF	OFF	ON
major 7 th	11	OFF	ON	OFF	ON
octave	12	ON	ON	OFF	ON
	12	OFF	OFF	ON	ON
	12	ON	OFF	ON	ON
	12	OFF	ON	ON	ON
2 octaves	24	ON	ON	ON	ON

Switch 5 Chooses the working direction of the Pedal

OFF = Pedal down => Pitch max.

Pedal up => Pitch 0

ON= Pedal down => Pitch 0

Pedal up => Pitch max.

Switch 6 Chooses the direction of pitch

OFF = Pitch down

ON = Pitch up

Switch 7 Chooses the resolution of pitch

OFF = semi-tone steps

ON = fine (100/125 steps)

5. Warranty / Support

The Controller Pedal XCC is covered by a 2-year warranty. Prostage shall not be liable if the damage was caused by inappropriate use or if the Controller Pedal was connected to anything else than the XTM / XTMpro adaptor or a device with a Prostage compatible Foot Controller connector. The detailed terms of the warranty can be downloaded from the Prostage website.

If you need technical support, please contact your local dealer or email to info@prostage.eu

